



F&F Filipowski L.P.
Konstantynowska 79/81, 95-200 Pabianice, POLAND
phone/fax (+48 42) 215 23 83 / (+48 42) 227 09 71
www.fif.com.pl; e-mail: biuro@fif.com.pl

BIS-419 24V
Bistable relay,
sequential, 4-functions



Do not dispose of this device in the trash along with other waste! According to the Law on Waste, electro coming from households free of charge and can give any amount to up to that end point of collection, as well as to store the occasion of the purchase of new equipment (in accordance with the principle of old-for-new, regardless of brand). Electro thrown in the trash or abandoned in nature, pose a threat to the environment and human health.



Purpose

The electronic bistable pulse relay BIS-419 allows lighting or other appliances to be switched on or off from several different points by means of parallel connected momentary (bell) control switches. The relay has 2 switching sections and allows to switch on or off in sequence 2 lighting circuits or other appliances from several different points.

Functioning

Power supply to the relay is indicated by the lighting of the green LED [U]. The sequential relay has 2 separate outputs R1 and R2. The state of the contacts (closed/open) is enforced sequentially according to the preset programme. Switching of the contacts to the next state takes place after another impulse of the control button. Activation of contacts R1 and R2 is signalled by lighting of corresponding red LEDs R1 and R2. After the power supply voltage decay, the contact status is reset. After the power supply voltage is restored, the relay starts from sequence no. 0.

Mounting

1. Disconnect the power supply.
2. Fix the relay on a rail in the control box.
3. Connect the supply wires to terminals 1-3, [for DC voltage: „+“ to terminal 3, „-“ to terminal 1].
4. Connect momentary switches connected in parallel to terminal 6 and the „+/~“ wire.
5. Connect the powered receiver of section R1 in series to terminals 11-12. Connect the powered receiver of section R2 in series to terminals 8-9.
6. Set the desired programme (sequence) using the knob on the front of the relay.



BIS-419 24V is not compatible with backlit buttons.



The maximum total backlight current of all connected buttons must not exceed 5 mA.

Wiring diagram

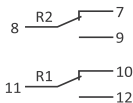
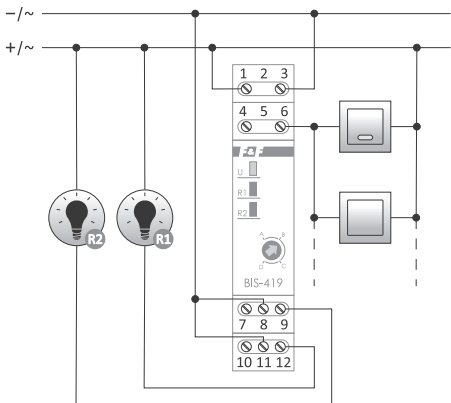

Example of connection with control pulse L

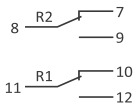
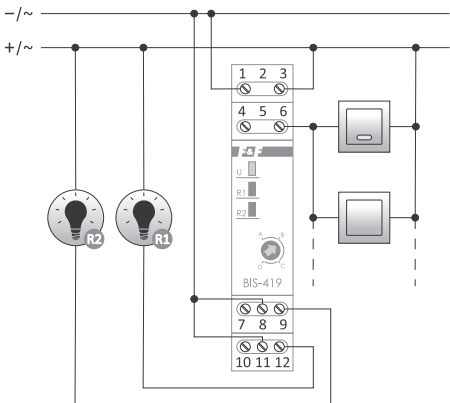

Example of connection with control pulse N

Diagrams

Sequence A

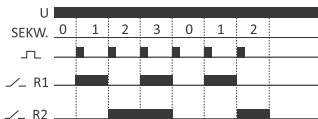

» Subsequent pressings of a button repeat the sequence 0-1-2-3.

Sequence B

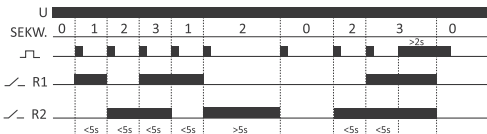

- » Pressing the button again in less than 5 seconds repeats sequences 1-3.
- » Pressing the button again after more than 5 seconds opens both contacts (sequence 0).
- » A long press of the button (in any sequence) opens both contacts (sequence 0).
- » After switching off both relays, pressing the button again restores the state from before switching off (state memory). This does not apply to relay power failure.

Sequence C



» Subsequent pressings of a button repeat the sequence 0-1-2.

Sequence D

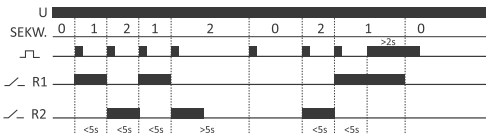





- » Pressing the button again in less than 5 seconds repeats sequences 1-2.
- » Pressing the button again after more than 5 seconds opens both contacts (sequence 0).
- » A long press of the button (in any sequence) opens both contacts (sequence 0).
- » After switching off both relays, pressing the button again restores the state from before switching off (state memory). This does not apply to relay power failure.

Technical data

power supply	9÷30 V AC/DC
contact	separated 2×NO/NC
maximum load current (AC-1)	2×16 A
control pulse current	<1 mA
activation delay	0.1÷0.2 s
power indication	green LED
power activation	2× red LED
power consumption	
standby	0.15 W
on	0.9 W
terminal	2.5 mm ² screw terminals
tightening torque	0.4 Nm
working temperature	-25÷50°C
dimensions	1 module (18 mm)
mounting	on TH-35 rail
ingress protection	IP20

Power table

				
tungsten	halogen	fluorescent	energy-saving	LED
2000 W	1250 W	1000 W	500 W	250 W

The above data are indicative and will heavily depend on the design of a specific receiver (that is especially important for LED bulbs, energy-saving lamps, electronic transformers and pulse power supply units), switching frequency and operating conditions.

For more information visit: www.fif.com.pl.

Warranty

The F&F products are covered by a warranty of the 24 months from the date of purchase. Effective only with proof of purchase. Contact your dealer or directly with us.

CE declaration

F&F Filipowski L.P. declares that the device is in conformity with the essential requirements of The Low Voltage Directive (LVD) 2014/35/EU and the Electromagnetic Compatibility (EMC) Directive 2014/30/UE.

The CE Declaration of Conformity, along with the references to the standards in relation to which conformity is declared, can be found at www.fif.com.pl on the product page.