



F&F Filipowski L.P.
Konstantynowska 79/81, 95-200 Pabianice, POLAND
phone/fax (+48 42) 215 23 83 / (+48 42) 227 09 71
www.fif.com.pl; e-mail: biuro@fif.com.pl

STR-421 24V
Roller blind controller
2-button



Do not dispose of this device in the trash along with other waste! According to the Law on Waste, electro coming from households free of charge and can give any amount to up to that end point of collection, as well as to store the occasion of the purchase of new equipment (in accordance with the principle of old-for-new, regardless of brand). Electro thrown in the trash or abandoned in nature, pose a threat to the environment and human health.



Purpose

The STR-421 controller is intended for controlling roller blinds (**UP/DOWN**) or other objects (e.g. gates) driven by a single-phase AC electric motor by means of momentary switches (e.g. bells). The controller may operate as a stand-alone device (intended for opening/closing one roller shutter), as well as it is possible to combine controllers into groups enabling central control of many roller shutters.

Functioning

Power supply to the controller is signalled by the lighting of the green U LED. The roller shutter motor is activated by momentarily applying voltage (L or N) to one of the control inputs. The motor is activated for a time pre-programmed by the user, allowing the roller shutter to be fully raised or lowered. The operation of the motor and the direction of the roller shutter's movement is signalled by the lighting of the corresponding red ↑ or ↓ LED. It is possible to stop the running roller shutter at the level selected by the user (incomplete opening or closing of

the roller shutter).

Control inputs controller

LOCAL CONTROL – group of push-buttons connected to terminals 7 and 9 controlling one roller shutter.

↑ – up (open); ↓ – down (close).

Pressing the local button switches the roller shutter on for movement in the set direction. If the roller shutter is already in motion, pressing the local control button will stop the roller shutter

CENTRAL CONTROL – a push-button group common to several controllers (minimum two) connected to terminals 4 and 6 controlling all shutters included in the central control system.

↑↑ – all up; ↓↓ – all down.

Pressing the central control button switches the roller shutters on for movement in the desired direction. If one of the roller shutters is already performing a movement in the same direction, the movement will continue. If it performs a movement in the opposite direction, the roller shutter will first be stopped and then switched on in the direction resulting from the command given to the central input.



The central control will only activate the roller shutters for movement in the selected direction. The roller shutter will only stop after the preset time has elapsed, or by pressing any button on the local control.

Wiring diagram

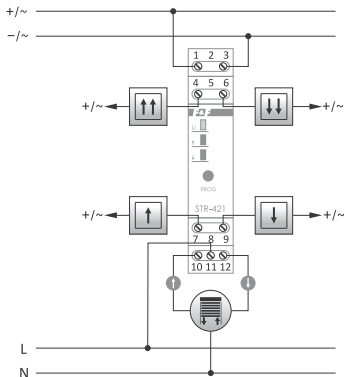

- 1-3 24 V AC/DC power supply
- 4 central control – **UP** ↑↑ direction
- 6 central control – **DOWN** ↓↓ direction
- 7 local control – **UP** ↑ direction
- 9 local control – **DOWN** ↓ direction
- 10 motor power supply – **UP** ↑ direction output
- 11 230 V (L) motor power supply
- 12 motor power supply – **DOWN** ↓ direction output



The control inputs can be supplied from the „+“ (DC) or „~“ (AC) wire. Select one control option for all inputs.

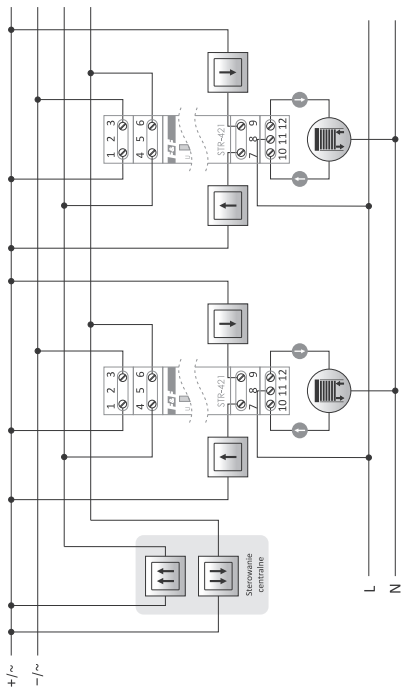

Example connection diagram for a system of 2 roller shutter controllers working with a common central control

Switch-on time programming

1. Press and hold the PROG button until the green U LED starts flashing.
2. Press the PROG (START) button again. The controller will start timing signalled by the green LED pulsing faster.
3. Press the PROG (STOP) button again. The controller will save the measured time. The programming mode is completed automatically (green LED U illuminates continuously).



If the timer is not started (**START**) within 30 seconds of entering the programming mode, the controller will exit the programming mode.



The maximum time to be programmed is 10 min. Attempting to set a time longer than 10 minutes will automatically exit the programming mode.



Entering the time programming mode is possible only when the roller shutter motor is switched off.



In programming mode, the controller does not react to external control signals.

Mounting

1. Disconnect power supply.
2. Mount the controller on a rail or in a distribution box.
3. Connect the power supply wires to terminals 1-3 as marked.



A group of controllers working with a common central control must be supplied from the same phase, e.g. L1 only.

4. Select the control option („+/~“ or „-/~“ pulse). Connect the local control and central control switches, respectively, to the terminals of the controller according to the function and to the selected wire (for DC supply to the „+“ wire; for AC supply to one common „~“ wire).



All control inputs of controllers working individually or in a group must have a common control pulse option „-“ all controlled from the „+“ (DC) wire or all from the same „~“ (AC) wire.



When selecting the DC power supply option, a „+“ pulse from the same power source (e.g. transformer) must be applied to the control inputs.



Connecting to the control inputs of the receivers voltage from another power source (e.g. from another transformer) may cause incorrect operation of the system and lead to an electrical short in the installation and to the destruction of the controllers.

5. Connect the controlled roller shutter motor to terminals 10 and 12 and to N respectively.
6. Connect the motor power supply (L) to terminal 11.
7. Connect power supply.
8. Programme raising/lowering time for the roller shutter. It is recommended that the programmed time is approx. 10 s longer than the actual raising/lowering time of the roller shutters.

Technical data

| | |
|---------------------------------------|------------------------------------|
| power supply | 24 V AC/DC |
| maximum load current (AC-1/AC-3) | 8 A/1.5 A |
| power of connected single-phase motor | 320 W |
| control | triggered by level L or N |
| control pulse current | <1mA |
| switch-on time (programmable) | 0 s ÷ 10 min. |
| power/programming indication | green LED |
| activation indication | 2× red LED |
| power consumption | <1 W |
| working temperature | -25 ÷ 50°C |
| terminal | 2.5 mm ² screw terminal |
| tightening torque | 0.4 Nm |
| dimensions | 1 module (18 mm) |
| mounting | on TH-35 rail |
| ingress protection | IP20 |



The controller uses a relay with a contact strength of 8 A for resistive load. Due to the inductive nature of the load introduced by the roller shutter motor, the contact should not be loaded with more than 1.5 A. This corresponds to a motor power of approx. 320 W.

Warranty

F&F products are covered by a 24-month warranty from the date of purchase. The warranty is only valid with proof of purchase. Contact your dealer or contact us directly.

CE declaration

F&F Filipowski L.P. declares that the device is in conformity with the essential requirements of The Low Voltage Directive (LVD) 2014/35/EU and the Electromagnetic Compatibility (EMC) Directive 2014/30/UE.

The CE Declaration of Conformity, along with the references to the standards in relation to which conformity is declared, can be found at www.fif.com.pl on the product page: www.fif.com.pl from the product subpage.

