



F&F Filipowski L.P.
Konstantynowska 79/81, 95-200 Pabianice, POLAND
phone/fax (+48 42) 215 23 83 / (+48 42) 227 09 71
www.fif.com.pl; e-mail: biuro@fif.com.pl

EPP-618

Electronic current
relay



Do not dispose of this device in the trash along with other waste! According to the Law on Waste, electro coming from households free of charge and can give any amount to up to that end point of collection, as well as to store the occasion of the purchase of new equipment (in accordance with the principle of old-for-new, regardless of brand). Electro thrown in the trash or abandoned in nature, pose a threat to the environment and human health.



Purpose

The EPP-618 is a current relay designed to control the values of the current flowing in the measured circuit with contact switching feature in the event of exceeding the current value above and below the set threshold values. The digital display allows the user to read the current value in the measured circuit on an ongoing basis and precisely program the values of parameters according to which it will operate.

Functioning

The relay is designed to work with a 5 A secondary current transformer or without a transformer, in which case its maximum current is 50 A.

The relay operates according to one of four operating functions: F1, F2, F3, and F4.

Function F1

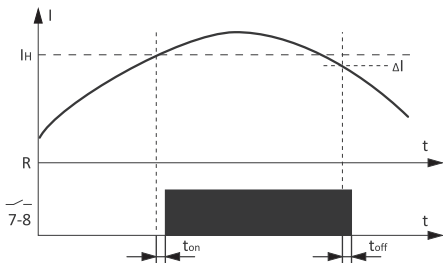

If the current in the measuring circuit exceeds the "Hi" setpoint, the relay contacts 7-8 will close and the contacts 9-10 open.

If the current in the measuring circuit is below the set value minus the hysteresis value, the relay contacts will return to their original position.

The moment of switching on and off the relay can be additionally adjusted in the range of 0.5÷10 s.

Function F2

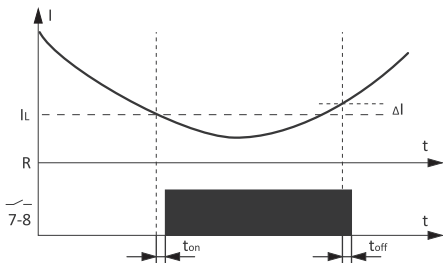

After the current falls below the "Lo" set value, the relay contacts 7-8 will close and the contacts 9-10 will open.

If the current in the measuring circuit is above the set value plus the hysteresis value, the relay contacts will return to their original position.

The moment of switching on and off the relay can be additionally adjusted in the range of 0.5÷10 s.

Function F3

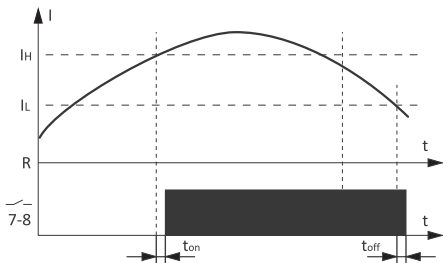

If the current in the measuring circuit exceeds the **Hi** setpoint, the relay contacts 7-8 will close and the contacts 9-10 open. The relay contacts in this function will only return to their original position if the current value is lower than **Lo**.

In this function, the current settings are not adjusted by the hysteresis value.

The moment of switching on and off the relay can be additionally adjusted in the range of 0.5÷10 s.

Function F4

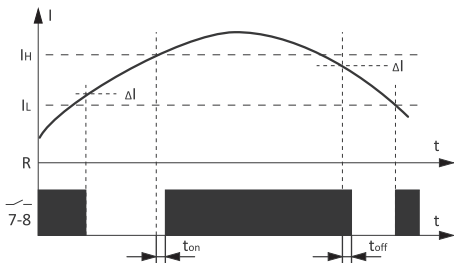

In this function, the relay operates in the so called "measuring window".

The relay will be switched on if the current in the measuring circuit is higher than the **Hi** setpoint. The relay contacts will return to their original position if the current drops below the setpoint minus the hysteresis value. But the relay will also be switched on if the current value is below the **Lo** setpoint.

In this case, the relay will be switched off if the current value in the measuring circuit increases above the **Lo** setpoint plus the hysteresis value.

The moment of switching on and off can be additionally adjusted with the **t_{ON}** or **t_{OFF}** time setting.

Display panel

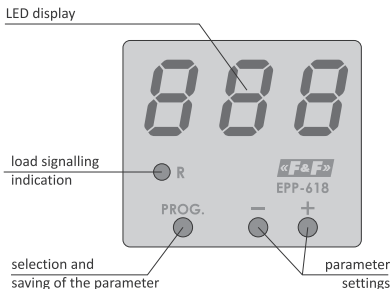

Programming the ratio value

1. Press and hold the **PROG** button for approximately 5 s.
2. The display will show the currently saved ratio value; the factory setting is 1, or 5/5.
3. Press **+** or **-** buttons to set the desired value, for example for 100/5 transformer you need to set 20.
4. Press the **PROG** button briefly. The value of the ratio will be saved in memory and the relay will automatically exit the programming function.

Programming the operating function

1. Press and hold the **+** button for approximately 5 s.
2. The display will show the currently set operating function; factory default is **F1**.
3. If the function is not changed, confirm with the **PROG** button.
4. If the function is to be changed, use the **+** or **-** buttons to set the given function and confirm it with the **PROG** button.
5. Then, depending on which function has been selected, set the value of **Hi** or **Lo** current, and each confirming the value with the **PROG** button.
6. Next, set the the t_{ON} and t_{OFF} values, also confirming each setting with the **PROG** button.
7. After saving the last value the relay will automatically exit the function setting mode.

Connection diagram

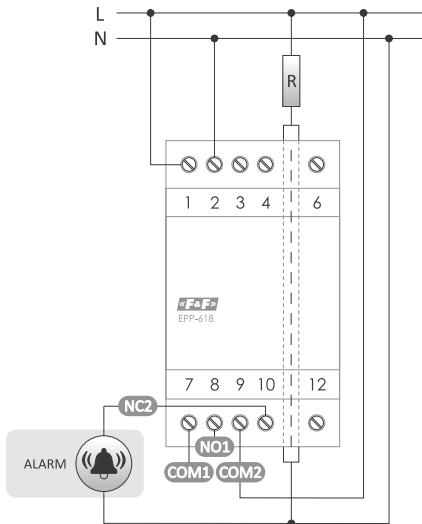

Direct mode

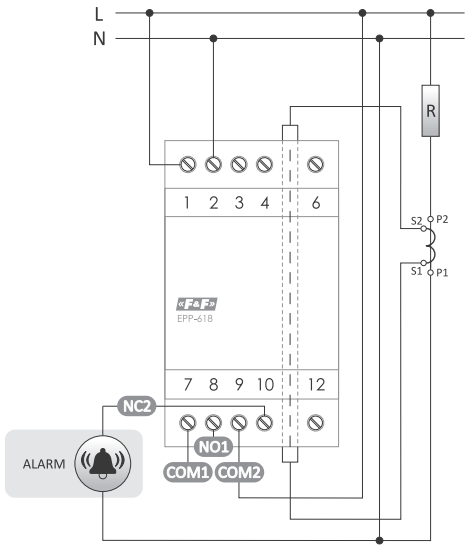

Measurement with a transformer

Technical data

power supply	195÷253 V AC
contact	separated 1×NO, 1×NC
maximum load current (AC-1)	2×8 A
adjustment range for direct measurement	0.5÷50 A
range of ratio settings	1÷999
switch-on time settings range	0.5÷60 s
switch-off time settings range	0.5÷60 s
constant hysteresis	10%
measurement error	<3%
diameter of the pass-through duct	ø4 mm
power consumption	4 W
working temperature	-25÷50°C
terminal	2.5 mm ² screw terminals
tightening torque	0.4 Nm
dimensions	3 modules (51 mm)
mounting	on TH-35 rail
protection level	IP20

Warranty

The F&F products are covered by a warranty of the 24 months from the date of purchase. Effective only with proof of purchase. Contact your dealer or directly with us.

CE declaration

F&F Filipowski L.P. declares that the device is in conformity with the essential requirements of The Low Voltage Directive (LVD) 2014/35/EU and the Electromagnetic Compatibility (EMC) Directive 2014/30/UE.

The CE Declaration of Conformity, along with the references to the standards in relation to which conformity is declared, can be found at www.fif.com.pl on the product page.

«F&F»[®]